

SERIES 111

8" Wide Surface or Pendant
Mounted Wraparound

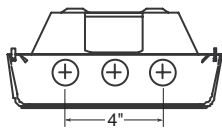
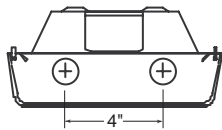
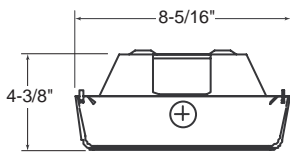
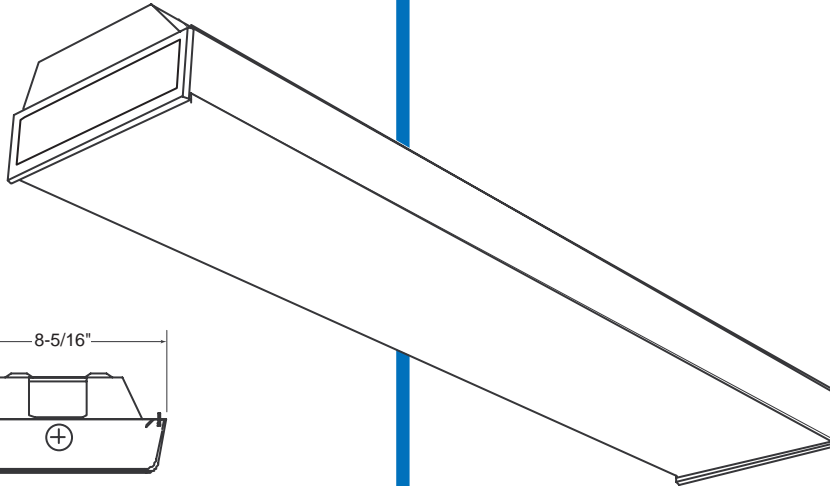

UNION MADE IN THE USA.

ORDERING:

NOMINAL SIZE	LAMPS	CATALOG NUMBER
9"X 4'	1-FO32	111-148T8
9"X 4'	2-FO32	111-248T8
9"X 4'	3-FO32	111-348T8
9"X 8'	2-FO32	111-148-2T8
9"X 8'	4-FO32	111-248-2T8
9"X 8'	6-FO32	111-348-2T8

INSERT VOLTAGE AT END OF CATALOG NUMBER

FEATURES:

- 1, 2, OR 3 LAMPS IN CROSS SECTION
- POST PAINTED HIGH REFLECTANCE POWDER COAT FINISH
- LINEAR SIDE PRISMS CONTROL BRIGHTNESS, PYRAMIDAL BOTTOM PRISMS MINIMIZE LAMP IMAGE
- INJECTION MOLDED END CAPS SONIC WELDED TO DIFFUSER
- SPRING LOADED HINGE / LATCH SYSTEM PERMITS DIFFUSER TO BE OPENED FROM EITHER SIDE
- COMPATIBLE WITH SURFACE, PENDANT OR CABLE MOUNTING SYSTEMS

NOTES:

1. 3 LAMP PENDANT MOUNT REQUIRES ONLY 2 STEMS
2. AVAILABLE IN T5 HIGH OUTPUT CONSULT FACTORY

MANUFACTURING
1715 KIBBY ROAD - MERCED - CALIFORNIA - 95340
(209) 723-9120 - FAX: (209) 723-9131

SALES OFFICE
14722 WICKS BLVD. - SAN LEANDRO - CALIFORNIA - 94577-6718
(510) 667-6950 - FAX: (510) 667-6959

BACK DETAIL

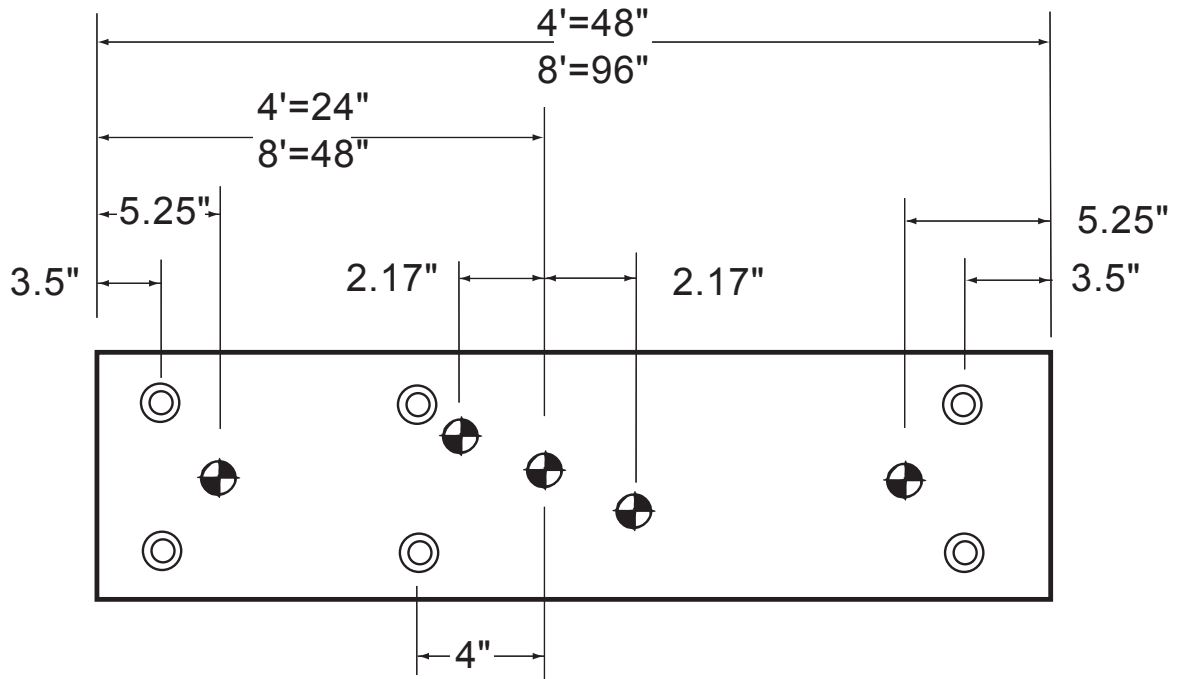
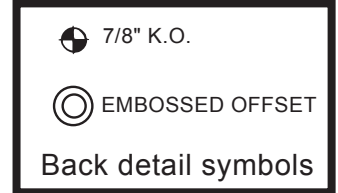

NOTE
All fixtures must be installed, wired and grounded in accordance with the National Electric Code and all other applicable codes.

!!! WARNING !!!
RISK OF FIRE OR ELECTRICAL SHOCK. ELECTRICAL PARTS MAY BE DAMAGED WHEN DRILLING OR USING "TEK" SCREWS FOR INSTALLATION OF MOUNTING HARDWARE. CHECK ENCLOSED WIRING AND COMPONENTS. USE CAUTION WHEN DRILLING "TEK" SCREWS INTO A BLIND AREA. TO PREVENT WIRING DAMAGE DO NOT EXPOSE WIRING TO SHARP EDGES.

