

SERIES 359

2 x 2 and 2 x 4
Side Direct - Indirect
Lay-in Troffer

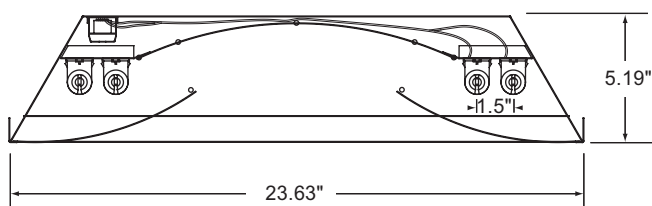
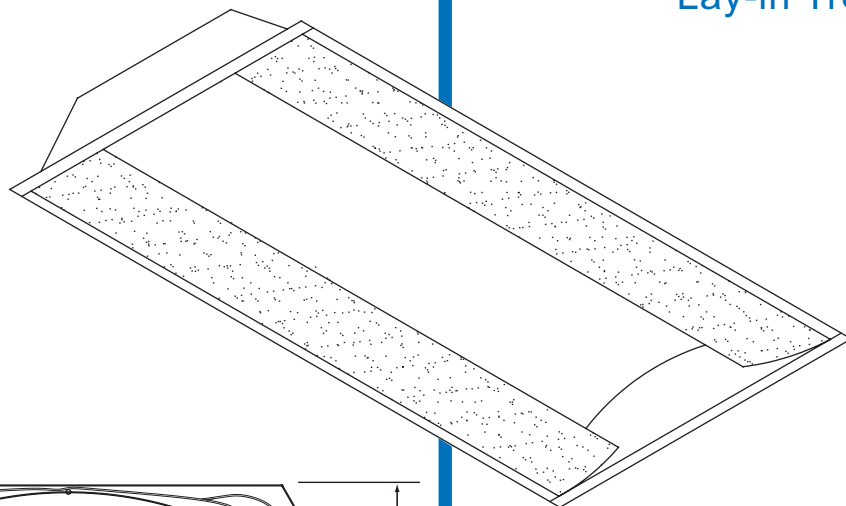

UNION MADE IN THE USA.

ORDERING:

NOMINAL SIZE	LAMPS	CATALOG NUMBER
2' X 2'	1-F017	359-PK-224T8
2' X 2'	2-F017	359-PK-448T8
2' X 4'	1-F032	359-PK-248T8
2' X 4'	2-F032	359-PK-448T8

2' X 2'	1-F24	359-PK-224T5-HO
2' X 2'	2-F24	359-PK-448T5-HO
2' X 4'	1-F54	359-PK-248T5-HO
2' X 4'	2-F54	359-PK-448T5-HO

INSERT VOLTAGE AT END OF CATALOG NUMBER

FEATURES:

- PERFORATED DIFFUSER ELIMINATES GLARE AND BALANCES THE BRIGHTNESS
- POST PAINTED SATIN WHITE FINISH PROVIDES A SOFTER LIGHT DISTRIBUTION
- REFLECTOR DESIGN IMPROVES OVERALL LUMINAIRE EFFICIENCY
- COMPUTER FRIENDLY ALTERNATIVE TO STANDARD RECESSED LIGHTING

TYPICAL APPLICATION:



- STANDARD 8' CEILING

NOTES:

1. AVAILABLE IN POWDERCOAT FINISH ONLY
2. AVAILABLE IN STANDARD T5 LAMP AND BALLAST CONFIGURATIONS

MANUFACTURING
1715 KIBBY ROAD - MERCED - CALIFORNIA - 95341
(209) 723-9120 - FAX: (209) 723-9131

BACK DETAIL

 WIRE ACCESS COVER PLATE
 7/8" K.O.
Back detail symbols

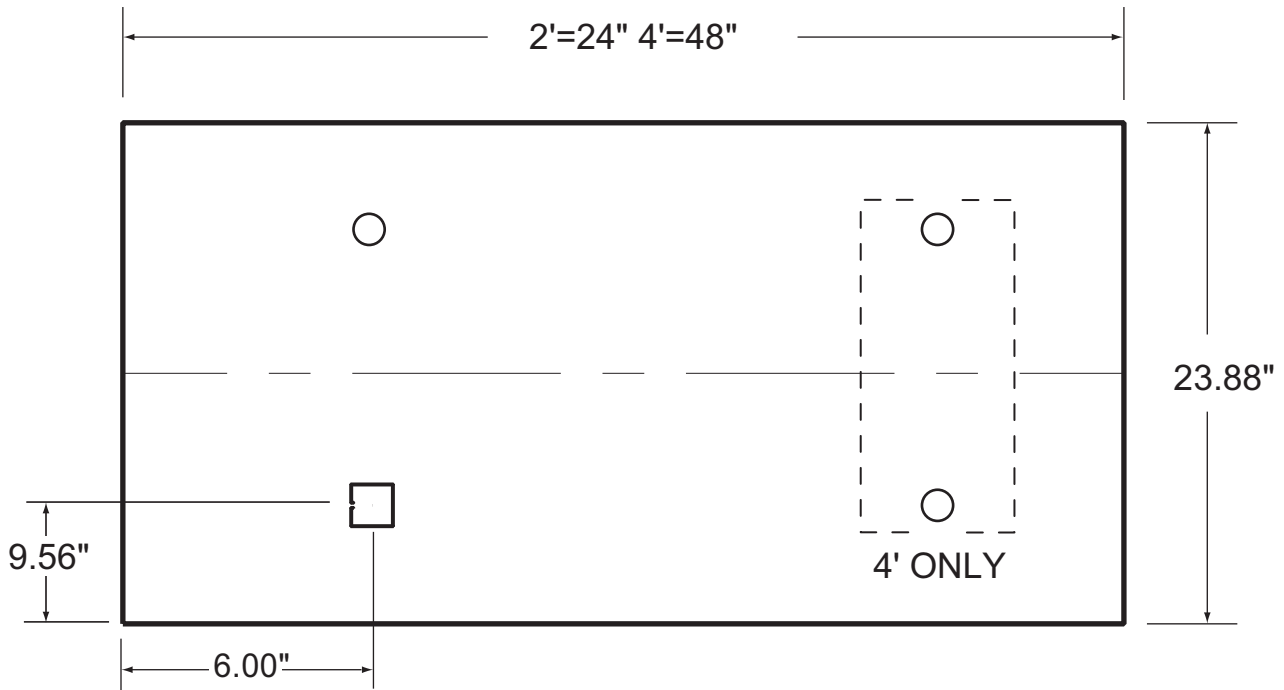

NOTE
All fixtures must be installed, wired and grounded in accordance with the National Electric Code and all other applicable codes.

!!! WARNING !!!
RISK OF FIRE OR ELECTRICAL SHOCK. ELECTRICAL PARTS MAY BE DAMAGED WHEN DRILLING OR USING "TEK" SCREWS FOR INSTALLATION OF MOUNTING HARDWARE. CHECK ENCLOSED WIRING AND COMPONENTS. USE CAUTION WHEN DRILLING "TEK" SCREWS INTO A BLIND AREA. TO PREVENT WIRING DAMAGE DO NOT EXPOSE WIRING TO SHARP EDGES.

